

# Food premises

## Design, construction and fit-out guide



This guide was collaboratively produced by the Southeast Queensland Food Safety and Public Health Working Group.

## *Contents*

1. About this guide	3
2. How to use this guide	4
3. Planning and approvals	5
4. Design and layout	7
5. General requirements	10
6. Floors	12
7. Walls and ceilings	16
8. Fixtures, fittings and equipment	21
Equipment for cleaning and sanitising	21
Equipment for food preparation and storage	24
9. Lighting	28
10. Ventilation	29
11. Hand washing facilities	32
12. Toilet facilities	34
13. Water supply	35
14. Sewage and wastewater disposal	36
15. Storage of rubbish and recycling materials	37
16. Storage facilities	38
17. Temperature measurement	39
18. Food transport	40
19. Mobile food vehicle	41
20. Bed and breakfast (B&Bs) and homestays	42
21. Appendix 1- key definitions	43
22. Appendix 2- example plans	45
23. Appendix 3- 2D example plans	46
24. Appendix 4- example plans of a mobile food vehicle	48

## *Table of Figures*

Figure 1: Example of correct flow of food and staff through a food premises	9
Figure 2: Plinth methods	14
Figure 3: Coving methods	15
Figure 4: Example of clearance for pipes and conduits	20
Figure 5: Examples of approved sneeze guards or protective barriers	26
Figure 6: Example plan of a mechanical ventilation system	31
Figure 7: Typical hand washing facilities	33
Figure 8: Example of cleaner's sinks	36
Figure 9: Example of an approved temperature measuring device accurate to +/- 1°C	39

## *Table of Tables*

Table 1: Suitability of floor finishes in food preparation areas	13
Table 2: Suitability of wall finishes for food premises	18
Table 3: Suitability of ceiling finishes for food premises areas	19
Table 4: Cleaning and sanitising facilities required for various food premises	23
Table 5: Minimum illumination level (lux) for food premises	28

# 1. About this guide

This guide is for businesses involved in the design, construction and fit-out of fixed and mobile food premises. It provides guidance to operators, architects, designers, builders, equipment manufacturers and other professionals associated with the design and construction of food premises.

It is based on the Food Safety Standard 3.2.3 (Food Premises and Equipment) and the Australian Standard 4674-2004 (Design, construction and fit-out of food premises). It aims to provide users with minimum requirements and best practice options to assist in producing food that is safe to eat and free from contamination. This guide is to be read in conjunction with an application package and guide for the licensing of fixed food premises as per the relevant State food legislation.

Food safety begins at the earliest planning stages. The correct fit-out will assist you in providing food premises that are easy to clean and maintain, and facilitate the production of safe food. There are cost advantages to the business in installing features to assist food safety practices at the time of construction.

This guide applies to all businesses used or intended to be used for the sale of food for human consumption including existing premises, new premises, domestic premises used for commercial purposes and mobile vehicles. Examples of these include cafés, hotels, bars, pre-packaged food premises, food sampling, restaurants, takeaway outlets, mobile food vehicles, caterers, and those food businesses operating from home.

This guide does not provide criteria for the design, construction and fit-out of temporary food premises such as market stalls.

This guide aims to ensure that food premises:

- are easy to clean and maintain
- have sufficient space, facilities and suitable equipment to produce safe food
- are provided with services such as potable water, effective sewage disposal, and sufficient light and ventilation for food handling operations
- provide facilities for staff to maintain standards of personal hygiene and equipment cleanliness that will protect food from contamination
- are proofed against harbourage and entry of pests

Food businesses are required under State food legislation to use premises and equipment that comply with Standard 3.2.3 of the Food Standards Code. This guide provides criteria on design and construction to assist with compliance with Standard 3.2.3 for new buildings and alterations to existing buildings.

Knowledge and understanding of the Food Safety Standards and Australian Standard 4674-2004 is necessary to adequately design, construct and operate food premises.

## 2. How to use this guide

This guide will provide you with solutions for designing or constructing food premises. This guide has been written based on:

- Food Safety Standard 3.2.3 (Food Premises and Equipment)
- Australian Standard 4674-2004 and other relevant Australian Standards

This guide will be useful if you are designing a café, restaurant, takeaway outlet or mobile food van. It also provides advice if you are a caterer running a food business from home, or operating a charity or non-profit organisation to sell food.

It is based on three concepts:

### 1. Food safety outcomes

- The food safety outcomes, intended by Food Safety Standard 3.2.3 (Food Premises and Equipment), can be found in the subheadings at the beginning of some sections of this guide.

### 2. Minimum requirements

Minimum requirements are measures that Council looks for as the minimum standard required to achieve compliance with Standard 3.2.3.

A number of acceptable solutions may be identified and listed for each outcome. Premises may need to use some or all solutions depending on the nature of the operation of the food business. Alternatively, you may be able to achieve compliance using a solution or method not listed in this guide. It is the applicant's responsibility to demonstrate to Council that any alternative methods of complying with the minimum requirements still meet the objectives of the Food Safety Standards. Before implementing alternatives, seek advice from Council.

### 3. Best practice

Best practice is where the solution is considered to be above the minimum requirements. Best practice solutions are optional. Not all best practice options are listed in this guide. For more information on the best practice options available, contact your local Council or industry association.

Where can I obtain copies of the Food Safety Standards? These Standards can be obtained by visiting [foodstandards.gov.au](http://foodstandards.gov.au).

### 3. Planning and approvals

When designing, building or fitting out new food premises or making changes to an existing one, your first step will be developing or obtaining existing plans. The plans allow Council to assess the proposed food premises before building commences. This saves architects, developers and food businesses time and money. Before building or renovation starts, copies of all plans - drawn to scale - must be lodged with Council.

#### General information required

You will need to provide the following information when you submit your plans:

- name, address and contact details of the architect, draftsman or shopfitter
- drawing scale and date when plans were drafted
- name of food business operator
- address of the premises and real property description (i.e. lot and registered plan number)
- proposed name of premises and intended nature of the food operation
- a document providing a brief overview of the types of activities and food processing to be carried out on the premises as well as the types of food involved in the activities and processes.

#### Types of plans required

You must submit copies of the following types of plans for your premises. Your architect, draftsman, builder or shopfitter will be able to assist you in providing these.

- Site plan - to a suitable scale (e.g. 1:100) (not needed for mobile food vehicles) - including car parking, refuse storage area, adjacent land uses, toilet facilities.
- Floor plan - to a suitable scale (e.g. 1:50).
- Sectional elevation plans - to a suitable scale (e.g. 1:50) showing all fittings and equipment.
- Hydraulic plans (plumbing details) - to a suitable scale (e.g. 1:50).
- Mechanical exhaust ventilation plans - to a suitable scale (e.g. 1:50).

## Details required on plans

You need to ensure the following details are included on the plans for your premises:

- finishes to floors, walls and ceilings
- layout of all equipment, benches, fittings and fixtures, and mechanical ventilation
- door and window openings
- where seating is provided for diners, the number of square metres of floor space available for dining and the number of persons to be catered for in this area
- customer and staff toilet details (if detached, provide the distance to the facilities and the number available for use)
- mechanical exhaust ventilation (refer to Figure 6)
- process flow, from product received through to end-product delivered

If you need further information on details required on plans, please contact Council.

## Other relevant approvals

When building your new premises or making changes to an existing food premises, it is essential that certain approvals are obtained before others. By obtaining all the required approvals before starting the construction, you will reduce the possibility of expensive mistakes and avoid potential breaches of the relevant legislation. The following checklist can be used as a reference when making an application for a new food premises. This will assist you in providing Council with relevant and correct information so your application can be processed without delay.

Design approval checklist. The following approvals (where applicable) must be obtained before starting construction of your food premises:

- Development assessment – check that under the Council Planning Scheme, a food business can operate on the site you are considering.
- Building – building approval is needed from a Council or private certifier.
- Plumbing – plumbing approval is needed from Council’s plumbing department and/or the relevant water authority.
- Trade waste – obtain approvals for grease traps from the relevant water and sewerage supply entity.
- Advertising signs – obtain approvals from Council.
- Footpath dining permit – obtain approvals from Council.
- Goods on footpath permit – obtain approvals from Council



## 4. Design and layout

### **Food Safety Standard 3.2.3 (Food Premises and Equipment), Division 2, Clause 3**

#### **Required outcome**

Food premises are required to be designed and constructed to:

- be appropriate for the types of food produced and activities conducted
- provide adequate space for all activities conducted and all equipment to be used or stored
- allow easy cleaning/sanitising procedures of all structures and equipment
- prevent entry of pests, dust, fumes, smoke and other contaminants
- exclude favourable sites for pests to harbour (live and breed)

#### **Minimum requirements**

Flow of food through a food premises

- The correct design and layout can help streamline work practices, reduce cleaning and maintenance, and prevent cross contamination.
- To prevent food contamination, premises must be designed so that the flow of food is in one direction from receipt to storage, preparation, packaging and serving, and finally to disposal.

#### **Adequate space**

- Adequate space is to be provided for all activities required to carry out the production of food on the premises.
- Storage of potentially hazardous food (hot and cold) must be adequate for the business to comply with Food Safety Standard 3.2.2 (Food Safety Practices and General Requirements).

#### **Cleaning, sanitising and maintenance**

- Layout and design of the premises must provide access for cleaning, sanitising and maintenance. Refer to section 8 “Fixtures, fittings and equipment” for more information.

#### **Food preparation areas**

- Adequate space must be provided for all food related activities.
- Exits must be in accordance with the Building Code of Australia. If the premises is an existing building, you may need to check with a building certifier to see if the exits comply.

#### **Dining areas**

- Adequate space must be provided for patrons and staff to access dining and serving areas. These areas must be designed in accordance with the Building Code of Australia.
- For cafés, restaurants and bars, a minimum floor area of 1 square metre (m<sup>2</sup>) per person accommodated must be provided in accordance with the Building Code of Australia.

### **Proofing against pests**

- Windows – must be kept closed or fitted with mesh screens that can be easily cleaned.
- Entrances and exits – must be fitted with self-closing solid doors, self-closing mesh screen doors or air/ plastic curtains, where applicable.
- Holes and spaces – if fittings penetrate walls and ceilings, they must be sealed. Spaces between equipment and walls must either be sealed or enough space provided for easy cleaning to prevent the harbourage of pests.
- Insect control devices – these can be installed but must not be located directly over the food preparation area or food storage areas. Insect control devices must be capable of retaining any insect within the device.

**Figure 1: Example of correct flow of food and staff through a food premises**

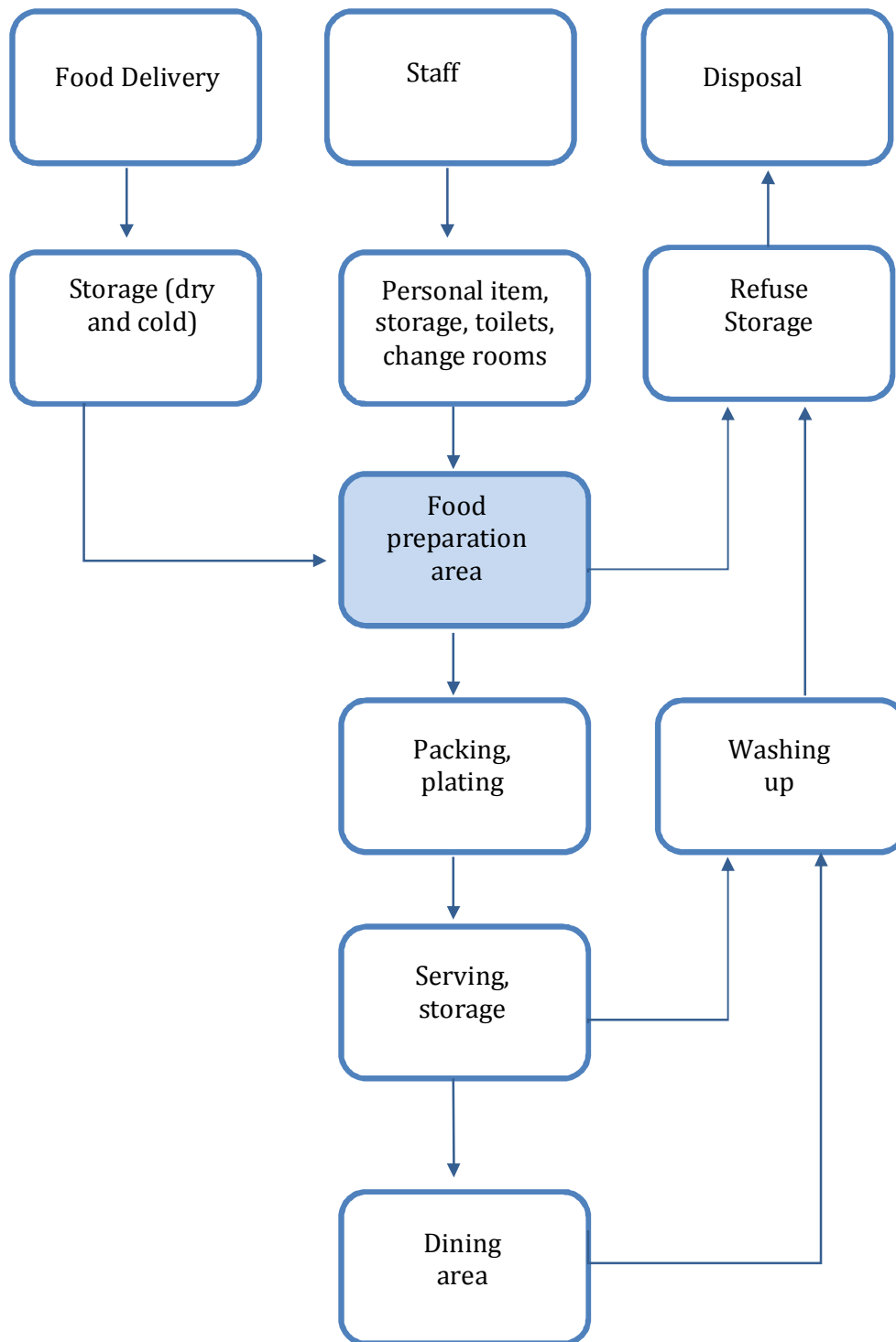

## 5. General requirements

### Food Safety Standard 3.2.3 (Food Premises and Equipment), Division 2, Clause 3

#### Required outcome

The design and construction of food premises must:

- be appropriate for the types of food produced and activities conducted
- provide adequate space for all activities conducted and for all equipment to be used or stored
- allow easy cleaning and sanitising of all structures and equipment
- prevent entry of pests, dust, fumes, smoke and other contaminants
- exclude favourable sites for pests to harbour (live and breed)

#### Minimum requirements

##### Appropriate for use

Food premises design and layout must be well-planned taking into consideration several important elements to ensure an effective and acceptable operation. Food premises design principles must accommodate safe flow of product and waste to minimise risks of food and equipment contamination. Separating particular processes in the food premises must be considered including:

- raw and cooked foods
- hand washing facilities
- wash areas
- storage facilities
- waste disposal areas
- toilet facilities

Important: A properly designed and operated food business will minimise the opportunity for food to become contaminated.

##### Adequate space

Proper planning of food premises will effectively designate adequate space and areas for food activities and storage of equipment. Storage areas must be constructed of materials which are durable and easily cleaned in line with requirements for floors, walls and ceilings.

Adequate space must be provided for:

- food delivery access
- dry goods - sufficient shelving space, pantry area and food grade containers for anticipated stock levels
- hot and cold food – adequate refrigeration, freezer and bainmarie (hotbox) food storage including display areas, food preparation areas and expected deliveries
- cleaning chemicals and equipment - separate lockers, cupboards, cabinets or designated storage areas
- waste - sufficient and separate waste containers for all anticipated waste including cardboard, glass, general waste, and waste oil storage; waste bins must be impervious, and designed to be easily cleaned to prevent the attraction of pests
- personal belongings – separate lockers, cupboards, cabinets or designated storage areas
- food contact utensils – adequate storage containers that are easily cleaned, preventing contamination

- equipment – sufficient floor, cupboard or shelving space for all cooking and food preparation equipment to be stored
- packaging - adequate storage located above the floor and stored to prevent contamination
- office and business equipment (used to run the business) – must be separate from the food storage and preparation areas to prevent contamination

Important: Contamination of food, equipment and non-food materials can occur when improper storage facilities are used.

### **Cleaning and sanitising**

The design of all food premises must provide for suitable access for effective and efficient cleaning procedures of all equipment, fittings, surfaces and areas. Refer to section 8 “Fixtures, fittings and equipment” for more information.

### **Entry of pests and harbourage**

All practical measures must be implemented to prevent entry of pests into food premises. In addition, the internal structures are to be finished and designed to prevent favourable sites for pest harbourage. The following may be implemented, when applicable, to satisfy this requirement:

- Installation of self-closing recessed doors or self-closing mesh screen doors with fitted weather strips to prevent pest entry into the premises.
- Mechanical air curtains and/or plastic curtains may be considered to minimise pest entry.
- All external windows must be fitted with close fitting mesh insect screens.
- All visible holes, service entries, gaps, crevices, cracks and voids are to be effectively sealed.

- Insect control devices may be used but must not be located above or immediately adjacent to food preparation, open food storage or cooking areas to prevent food contamination. The insect control device must be designed to capture and contain all insects within the device, operated and installed according to manufacturer’s specifications, and cleaned on a regular basis.
- The use of chemical sprays (either mechanical or manual) are not permitted in food preparation working areas, over or near exposed food, cleaning equipment, unwrapped packaging and servery areas.
- Installation of pest-proof roller doors. This must include:
  - installation of weather strips at the bottom of the roller shutters
  - sides of the roller shutters fitted tightly into the housing
  - installation of a pest-proof material at the top of the roller shutter to fill the gap usually left when the shutter is closed overnight

## 6. Floors

### **Food Safety Standard 3.2.3 (Food Premises and Equipment), Division 3, Clauses 9 and 10**

#### **Required outcome**

Floors must be designed and constructed so that they:

- are appropriate for the activities conducted on the premises
- can be effectively cleaned
- do not absorb grease, food particles or water
- are laid so there is no ponding of water
- are unable to harbour pests

#### **Minimum requirements**

##### **Floor finishes for food preparation areas**

- Floors must be finished with an approved material and laid to a smooth surface, free from cracks and crevices. Table 1 shows the suitability of floor finishes in food preparation areas.
- Floor finishes should be light coloured to facilitate effective cleaning.

##### **Food preparation areas**

Floors are to be finished with one or a combination of the following materials:

- sealed quarry or ceramic tiles
- stainless steel, non-slip
- laminated thermosetting plastic sheeting
- epoxy resin
- steel trowel case-hardened concrete or similar impervious material
- floor tiles grouted with epoxy grout and finished flush with the surface of the tiles
- floors, draining to floor waste, sufficiently graded (at least 1:100)

Feather edge skirting not permitted.

##### **Coving**

Coving should be provided in new premises in areas where floors are intended to be or likely to be cleaned by flushing with water. In existing premises it should not be necessary to install coving unless there are problems with cleanliness.

##### **Food storage areas**

- Floors in storage areas for unpackaged food must meet the same requirements as floors in food preparation areas.
- Floors in storage areas for packaged food must have an impervious finish.

##### **Plinths**

- Plinths can be used to hold heavy equipment that is unable or difficult to move for cleaning. Refer to Figure 2.
- Plinths are to be constructed to meet the same specifications as floors; must be solid; without voids and be an integral part of the floor; have the same top area finish as the floor; be rounded at all exposed edges and coved; be approximately 100 millimetres (mm) high.
- The base of the equipment is to be sealed to the plinth and overhang to prevent liquid, food or floor washing to access underneath the equipment.
- Alternatives to the use of plinths include metal legs, castors and brackets. Refer to section 8 “Fixtures, fittings and equipment” for details.

**Table 1: Suitability of floor finishes in food preparation areas**

Finish		Water areas	Food preparation	Vegetable preparation	Servery	Store room	Chillers/ freezers	Bin store	Eating areas	Comments
Stainless steel non-slip	Steel	√	√	√	√	√	√	√	√	Welded joints
Ceramic tiles		√	√	√	√	√	√	√	√	Epoxy grout
Quarry tiles		√	√	√	√	√	√	√	√	Sealed
Steel trowel case hardened concrete				√		√	√	√		Smooth sealed; finish no joints
Carpet/ carpet tiles									√	
Wooden flooring									√	Sealed
Poly vinyl sheet		√	√	√	√	√	√	√	√	Heat welded joints
Vinyl tiles				√	√	√	√	√	√	
Plastic matting					√				√	
Cork tiles									√	Sealed
Epoxy resin		√	√	√	√	√	√	√	√	

Note where it is not practical to use one of the other floor finishes, the use of steel trowelled case hardened concrete that is smooth and impervious to moisture may be used in wet washed, food preparation and servery areas

## Best practice

### Coving

- To facilitate effective and easy cleaning, it is highly recommended that coving be installed at the intersections of walls to floors and floors to plinths in food preparation areas.
- Coving is to be installed in accordance with Figure 3, or installed in accordance with other methods which achieve the same outcome.

Handy hint: Coving is highly recommended to assist with cleaning and to ensure dirt and grease does not build up.

**Figure 2: Plinth methods (not to scale)**

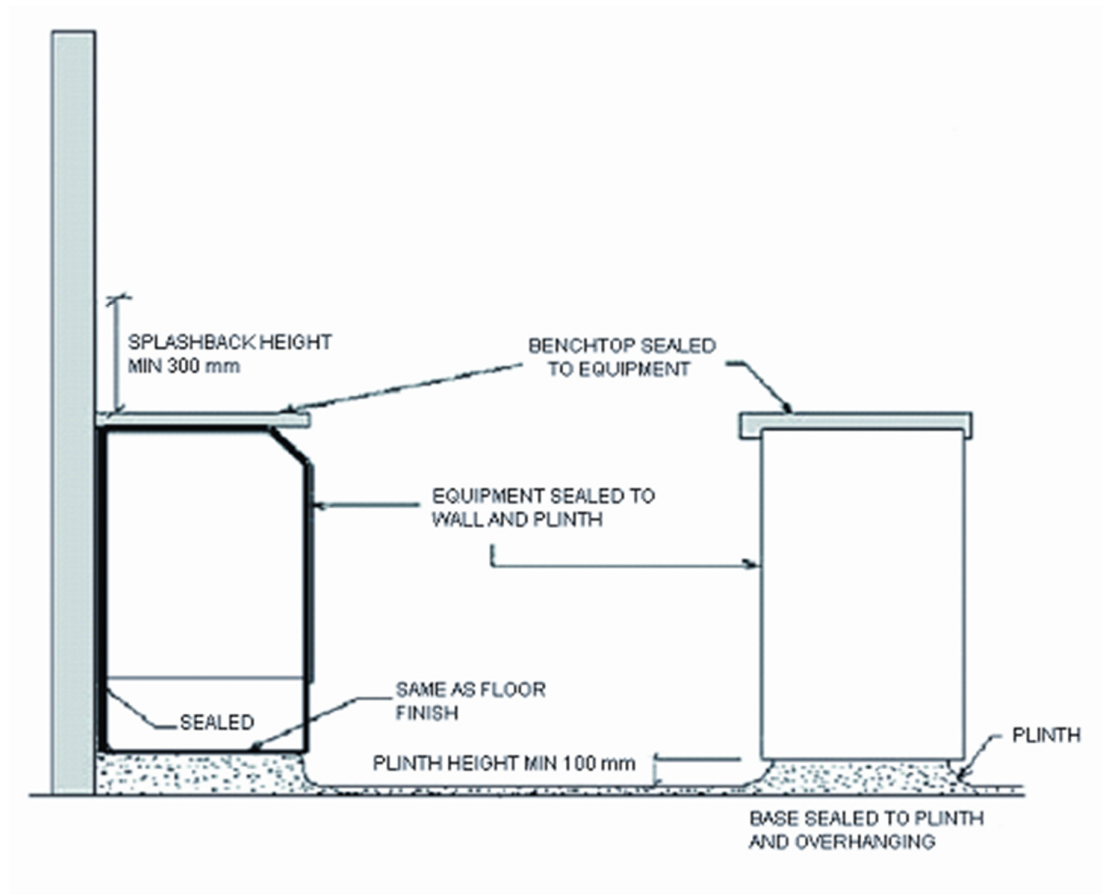



**Figure 3: Coving methods (not to scale)**

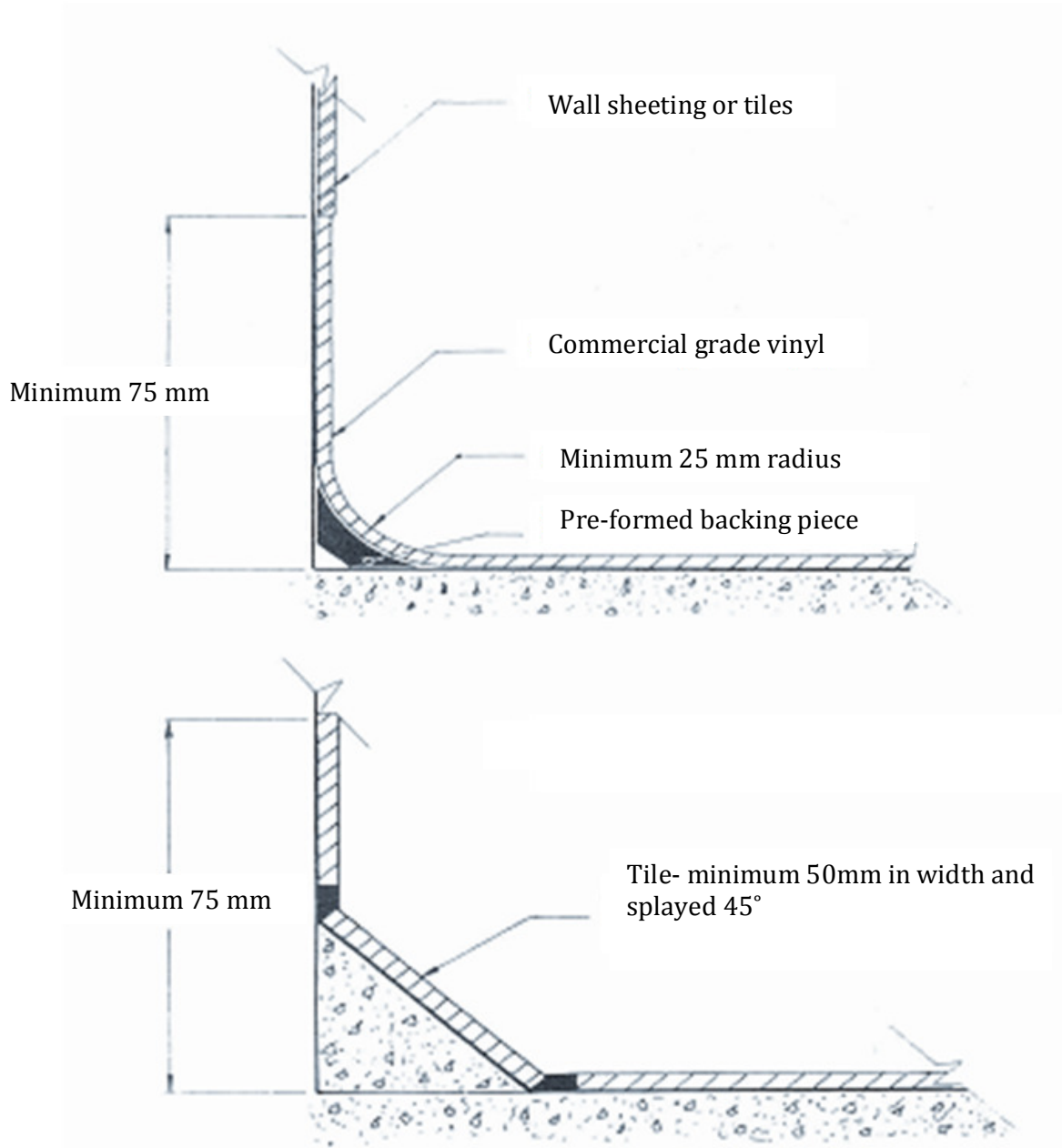

## 7. Walls and ceilings

### Food Safety Standard 3.2.3 (Food Premises and Equipment), Division 3, Clauses 9 and 11

#### Required outcome

Walls and ceilings must be constructed to:

- be appropriate for activities conducted on the food premises
- protect food from contamination where necessary
- prevent the entry of dirt and dust
- prevent absorption of grease, food particles and water
- ensure easy and effective cleaning
- prevent harbourage for pests

#### Minimum requirements

##### Wall construction

- Walls are to be solid and of framed or preformed panel construction where voids can be filled with a suitable material.
- Joints between preformed panels must be filled and finished flush with the surface of the sheeting material.
- Cover strips are not permitted in food preparation areas as they allow dirt and grease to accumulate.

Handy hint: Solid construction is defined as having structural integrity to support ceiling, heavy equipment and withstand the physical wear and impacts from its environment. Should be smooth, and unable to absorb grease, food particles, moisture and dirt allowing for easy and effective cleaning. Must prevent the entry of pests, vermin and dust (or other potential contaminants).

##### Wall finishes for food preparation areas

- Walls are to be finished with a light coloured, high gloss, washable, easy-to-clean surface.
- Walls in food preparation areas are to be finished with an approved material such as:
  - glazed tiles (not suitable for wash down areas) – preferably laid to a minimum height of 2 metres (m)
  - stainless steel or aluminium sheeting
  - acrylic or laminated plastic sheeting
  - polyvinyl sheeting with welded seams
  - plaster board
  - cement render may be appropriate in some circumstances
- Any finish continued above ceramic tiles must be finished flush with the tiles to prevent the accumulation of dirt and grease.
- Architraves, skirting boards, picture rails or similar protrusions on the walls in food preparation areas are not recommended.
- Walls at the rear of cooking appliances must be surfaced with an impervious material, such as stainless steel, which extends from the canopy to the floor. Where a cooking appliance is sealed to the wall, the material must be lapped over the top edge of the appliance to provide a grease and vermin proof seal. Cooking appliances must only be sealed to walls made of a non-combustible material.
- Splashback walls at the rear of benches, sinks and hand basins must be surfaced with an impervious waterproof material to a minimum height of 300mm.
- In wet areas, the bottom plate in all timber framed partitions in food preparation areas must be placed on a “dwarf” wall constructed of concrete or similar material, and constructed approximately 70mm above the floor.

## **Ceilings**

- The ceiling height in a food premises must not be less than 2.4m
- Ceilings must be free of open joints, cracks and crevices.
- The intersection of walls and ceilings are to be tight jointed, sealed and dust-proof.
- The ceiling must be finished with a material that is washable and impervious.
- Ceilings must be finished in a light colour to facilitate cleaning.
- Approved materials for ceilings include:
  - fibrous plaster
  - plasterboard
  - fibrous cement
  - cement render with steel trowel
- Drop in panels are not to be used in food preparation or display areas.

## **Pipes, conduits and wiring**

- Must be concealed in floors, plinths, walls and ceilings, or fixed on brackets providing at least 25mm clearance between the pipe and adjacent surfaces, and 150mm between the pipe or conduit and adjacent horizontal surfaces. See Figure 4.
- Service pipes, conduits and wiring are not to be placed in the recessed toe space of plinths or equipment.

**Table 2: Suitability of wall finishes for food premises**

Finish	Wet washed areas	Food preparation	Vegetable preparation	Servery	Store room	Chillers/ freezers	Bin store	Eating areas	Comments
Stainless Steel	√	√	√	√	√	√	√	√	Welded joints Waterproof screw covers
Ceramic tiles	√	√	√	√	√	√	√	√	Epoxy grout
Vinyl sheets	√	√	√	√	√	√	√	√	Heat welded joints
Painted plaster					√		√	√	Smooth finish
Feature brick								√	
Aluminium sheet	√	√	√	√	√	√	√	√	Welded or sealed joints
Steel Sheet							√		Welded or sealed joints
Trowelled cement		√	√	√	√	√	√	√	Polished surface
Wood panelling								√	Wood sealed
Painted brickwork					√		√	√	Flush joints and solid surfaces
Concrete					√		√	√	Sealed smooth surface
Pre-formed panels	√	√	√	√	√	√	√	√	H bars joints mastic sealed. In wet areas/ food preparation shall be integrated into a dwarf wall or set on plinth

**Table 3: Suitability of ceiling finishes for food premises areas**

<b>Finish</b>	<b>Wet areas</b>	<b>Vegetable preparation</b>	<b>Servery</b>	<b>Store room</b>	<b>Chillers/ freezers</b>	<b>Bin store</b>	<b>Eating areas</b>	<b>Comments</b>
Painted plaster	√	√	√	√		√	√	Smooth finish
Steel Sheet	√	√	√	√		√	√	
Trowelled cement	√	√	√	√		√	√	Polished surface
Wood panelling							√	Sealed surfaces
Concrete	√	√	√	√		√	√	Sealed smooth surface
Pre-formed panels	√	√	√	√	√	√	√	
Acoustic panels							√	Suspended T-bars
Decorative panels							√	

Figure 4: Example of clearance for pipes and conduits (not to scale)

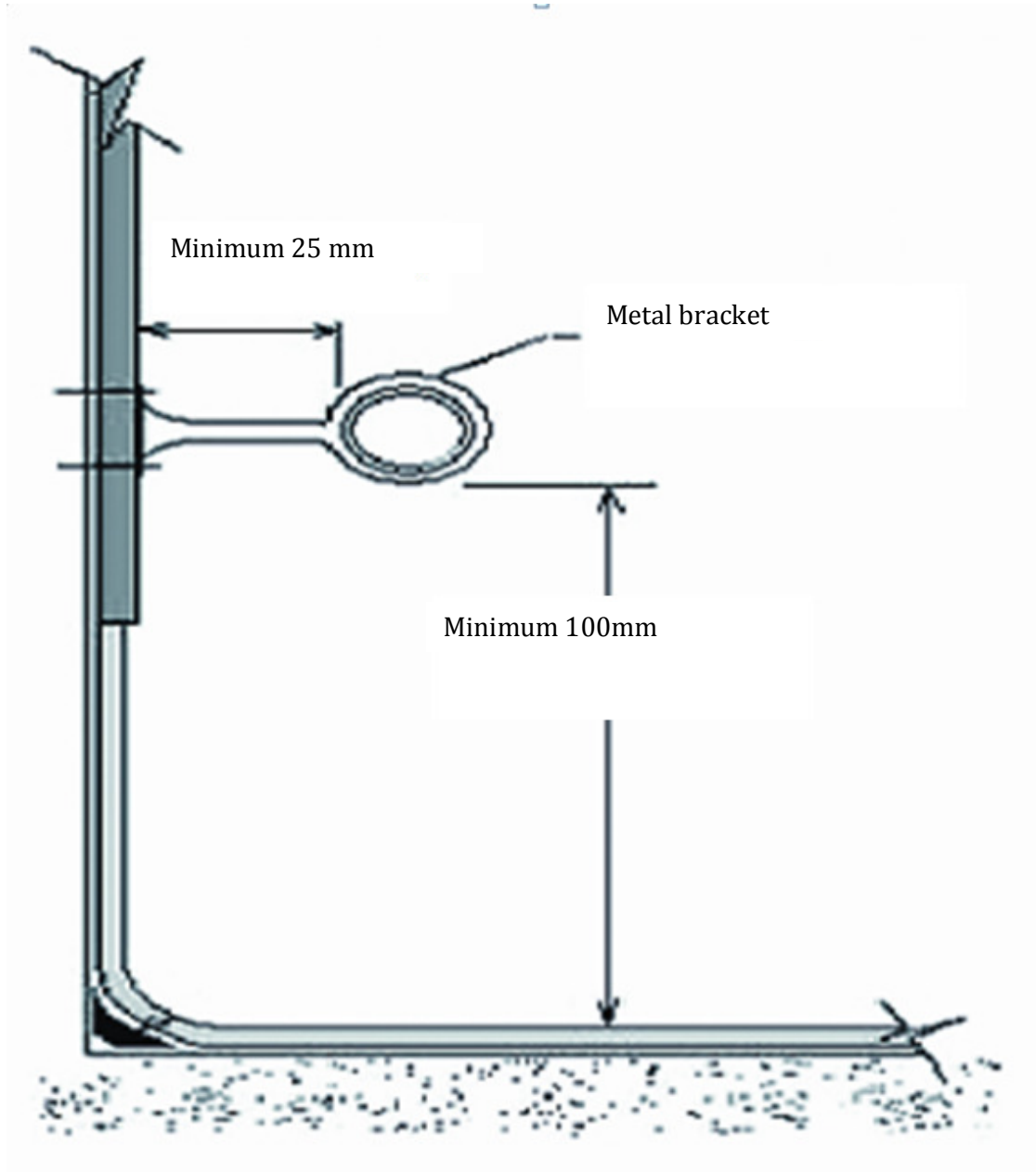

## 8. Fixtures, fittings and equipment

### **Food Safety Standard 3.2.3 (Food Premises and Equipment), Division 4, Clause 12**

#### **Required outcome**

Fixtures, fittings and equipment must be:

- adequate for the production of safe and suitable food
- fit for their intended use

Fixtures, fittings and equipment, and food contact surfaces must be designed, constructed, located and installed so that:

- there is no likelihood they will contaminate food
- they can be easily and effectively cleaned (including eating and drinking utensils)
- surrounding surfaces can be easily and effectively cleaned
- they do not provide harbourage for pests

### **Equipment for cleaning and sanitising**

#### **Minimum requirements**

##### **Facilities**

Table 4 shows the different facilities required when undertaking food preparation, cleaning and sanitising activities.

##### **Hot water supply**

- All equipment for cleaning and sanitising is to be connected to a continuous supply of hot and cold potable water and to an approved drainage system.
- Sinks must be supplied with water at a temperature of not less than 43 degrees Celsius (°C) for washing and 77°C for sanitising (if sanitising takes place in the sink).

- The best temperature for washing utensils in the food service industry is between 54°C and 60°C. Temperatures higher than this tend to bake food residue on.

##### **Double and triple compartment sinks**

- Where a double or triple compartment sink is used for hot water sanitising, rinsing baskets and heating elements capable of maintaining the water temperature at a minimum of 80°C are to be provided.
- Loading space and draining or drying space is to be provided.
- Chemical sanitising is permissible. A food grade sanitiser must be used if items are not rinse.

### **Dishwashers and glass washers**

Dishwashers and glass washers should meet the following requirements:

- be capable of completely washing and rinsing in one operation
- be designed so that all utensils, after rinsing, are dry by the end of the operating cycle
- be fitted with control devices to ensure the machine will not operate until the rinsing water is at the required temperature
- brushes are not permitted as part of the mechanism
- utensils to be rinsed for at least 10 seconds with:
  - water at a minimum of 50°C containing a minimum of 50 milligrams per kilogram (mg/kg) sodium hypochlorite, or
  - water at a minimum temperature of 80°C
  - be fitted with a thermometer clearly visible to the operator indicating temperature for the washing and rinsing operation or be fitted with an automatic pilot light visible to the operator which indicates that the water in the heating device has reached the correct temperature
  - be equipped with a water heating device or be supplied with water from an individual hot water source
  - be provided with an approved exhaust ventilation system (if required)
  - be designed to use chemical sanitisers
  - include a rinse cycle to ensure no chemical residue remains

### **Double bowl sinks**

Double bowl sinks must have the following requirements:

- be constructed of stainless steel
- have a minimum bowl size of 450mm x 300mm x 300mm to enable cleaning of large pots and equipment
- be fitted with a draining area at each end
- have a splashback as part of the unit, 300mm up the wall
- where draining racks are provided above sinks, they must be of stainless steel construction (preferable to have walls behind a drainage rack made of stainless steel sheeting or tiles to prevent damage to the wall)

### **Food preparation sinks**

Where food preparation requires the washing of food and immersion in water, a designated food preparation sink must be provided for this purpose. Designated food preparation sinks must be separate from all other sinks.



**Table 4: Cleaning and sanitising facilities required for various food premises**

Food premises activities	Minimum facilities for cleaning equipment and preparing food
No preparation/minor handling of pre-packaged food	Single bowl sink (capable of immersing the largest equipment)
Handling unpackaged food	<ul style="list-style-type: none"> <li>▪ Double bowl sink (capable of immersing the largest equipment), or</li> <li>▪ Dishwasher/ glass washer and single bowl sink (where all food contact equipment will fit in the dishwasher), or</li> <li>▪ Double bowl sink and a dishwasher/ glass washer (where some equipment has to be washed/ sanitised in the sink)</li> </ul>
Where food is prepared by immersion or rinsing in water	Designated food preparation sink
Where floors and equipment are to be hosed	Designated hose connection

## Equipment for food preparation and storage

### Minimum requirements

#### Temperature gauges

- Hand held probe thermometers that are accurate to +/- 1°C are to be used to measure the internal temperature of the food.

#### Chilled and frozen storage

- All cold storage and cold display equipment must be large enough for the business to adequately store cold food.
- All cold storage and display equipment must keep potentially hazardous food at a temperature of 5°C or less.
- Refrigerators, cold rooms and blast chillers must be capable of reducing the temperature of potentially hazardous food in accordance with Clause 7 of Food Safety Standard 3.2.2 (Food Safety Practices and General Requirements).
- Freezers are to keep food frozen.
- The recommended temperature for frozen food is at least -15°C.

#### Cold and frozen storage rooms

- Cold and frozen food storage room walls are to be lined with a smooth and impervious material and all joints sealed.
- Floors are to be a smooth and impervious material, and coved at the floor to wall junction.
- Floors are to be graded to the door opening and to a floor waste located outside the room, which is connected to the sewerage network or effluent disposal system.
- Doors must be able to be opened from the inside and an alarm fitted in accordance with the Building Code of Australia.
- Shelving is to be made of galvanised piping (with sealed ends), stainless steel or other suitable materials; must be easy to remove for cleaning; is clear of walls for cleaning and maintenance; and the lowest shelf must be off the floor to allow for easy cleaning.
- Cold and freezer rooms are to be located away from the wall to enable access for cleaning, or sealed to the walls to prevent harbourage of vermin.
- Voids above cold and freezer rooms are to be pest proofed.
- External cold and freezer rooms are not permitted unless an approved enclosed access is provided (bulk cold/freezer stores and packaged food are exempt from this requirement).
- Motor units should be located external to the premises or, if located inside the food premises, must be supported on metal legs to allow for easy cleaning.

Handy hint: The position of externally mounted cold and freezer room motors must be carefully considered to prevent any noise nuisance to nearby residences and businesses. Units should be placed away from neighbouring bedroom windows, office windows, multiple walls and corners.

### **Preparation, cooking, and hot and cold display**

- All equipment for preparation, cooking and display must be constructed to be easily and effectively cleaned with no open cracks, crevices and joints where food and liquids can collect.
- Hot and cold food storage and display units must be capable of maintaining food under temperature control (i.e. 5° C or below, or, 60° C or above).

### **Benches, tables and preparation counters**

- Benches and tables are to be constructed so that they are able to be easily and effectively cleaned. Examples include laminated timber, plastic or stainless steel with pest-proof joints.
- Benches fixed against a wall must be sealed to the wall with an appropriate material. Benches subjected to heat should be lined with stainless steel.
- Sandwich counters, used to prepare food in front of customers, must be fitted with a protective barrier between the customer and the food.
- Preparation benches and cooking equipment less than 1.5m from customers must be fitted with sneeze guards constructed of glass or perspex, and designed to prevent contamination from customers.
- Equipment placed on bench tops must be easy to move by one person or sealed to the bench top.

### **Cooking equipment**

- Stoves and cooking appliances are to be kept clear of walls to enable access for cleaning or built into walls and completely pest proofed.
- Appliances must be either:
  - placed apart to prevent grease and food accumulation
  - placed together with the gap between the appliances flashed or sealed to prevent food, liquid or grease accumulating, or placed on castors to allow the appliance to be moved for cleaning.
- Appliances must be kept clear of cupboards or benches not used in connection with the cooking operation.
- Deep frying equipment must be thermostatically controlled to prevent a fire hazard from the overheating of cooking oils.
- Where cooking is carried out, the premises must be equipped with a suitable fire extinguisher or fire suppression system located near the cooking equipment.

### **Miscellaneous**

- Post-mix/syrup and ice machines must be located in a fully-lined and sealed food grade room (i.e. they must not be stored outside the food premises or in the open).
- Food conveyors must be constructed of smooth impervious surfaces, free from cracks, crevices and open joints, with access provided for easy cleaning.

**Figure 5: Examples of approved sneeze guards or protective barriers on salad bars and food preparation bench**

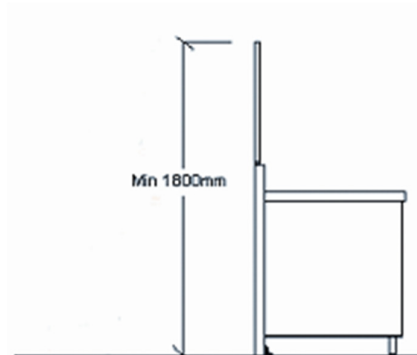
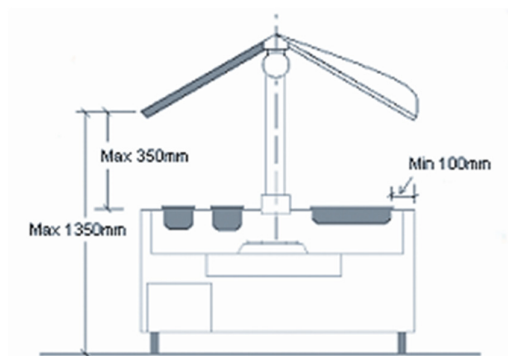

### Display cabinets

- Sliding doors to display cabinets must have bottom guides or runners terminating not less than 25mm from each end of any door opening for easy cleaning.
- Self-service food bars must be fitted with sneeze guards designed to prevent contamination (from a customer's mouth or nose) affecting the food as per Figure 5.
- Window displays of wet foods, such as meat and fish, must be covered at all intersections and installed in accordance with Australian Standard 3500.2:2003 (Plumbing and drainage - Sanitary plumbing and drainage).

### Supports for equipment

Including plinths, the following can be used to support heavy equipment:

- metal legs - are to be smooth and sealed to prevent the access of pests and be approximately 150mm high for easy cleaning
- castors or wheels - must be capable of supporting and moving fully-loaded equipment
- brackets - sinks, tubs, wash basins, tables, benches, shelving and similar fittings must be supported on stainless steel, galvanised tubing with sealed ends or solid steel brackets securely fixed into the wall or on approved frames
- unsealed timber frames and supports are not permitted

### **Shelving**

- Must be smooth and non-absorbent; free from joints, cracks and crevices; and able to be easily cleaned.
- The lowest shelf must be at least 150mm off the floor to allow easy cleaning underneath.
- Approved materials must be used, such as galvanised piping, stainless steel or laminated plastic.
- Shelves are to be sealed to the wall or kept clear of walls to allow easy access for cleaning.

### **Windows and ledges**

- Should be located at least 300mm above the bench, sink or hand basin.
- Ledges must be splayed at a 45° angle to prevent accumulation of dirt, food and grease.

### **Cupboards and cabinets**

- Where free standing, all surfaces including the back are to be smooth and washable.
- Boxed in compartments such as bases to cupboards and bench units should not be used.

### **Best practice**

#### **Temperature gauges**

- Temperature gauges must be accurate to +/- 1°C and must be fitted to each hot and cold storage or display unit; must be clearly visible and fitted to show the internal operating temperature in the:
  - coolest part of the appliance for hot display
  - warmest part of the appliance for cold storage and display

Note: Fixed thermometers in units are to be used as a guide only. The use of probe and infra-red thermometers will give an accurate indication of food storage temperatures.

#### **Areas above cold/freezer rooms**

The area above cold/freezer rooms (if exposed) must be fully-enclosed with vermin-proof access hatches to allow pest control treatment to be undertaken.

## 9. Lighting

### Food Safety Standard 3.2.3 (Food Premises and Equipment), Division 2, Clause 8

#### Required outcome

Food premises must have a lighting system that provides sufficient natural or artificial light to enable staff to conduct activities safely within the food premises.

#### Minimum requirements

##### Lighting system

A food premises must provide sufficient lighting to adequately illuminate all areas of the food premises to enable food handlers to:

- readily see whether areas and equipment are clean
- detect signs of pests
- clearly see the food and equipment they are handling

##### Light fittings

In areas where food is handled or stored, light fittings must be designed with the following specifications:

- light bulbs/tubes are to be shatterproof or fitted with approved light diffusers (covers or shields) to prevent contamination of food by glass from a broken light globe/ tube
- light fittings must be free from any feature that would collect dirt or dust, harbour insects or make the fitting difficult to clean
- light fittings must be recessed into ceilings or equipment where possible
- heat lamps must be protected against breakage by a shield extending beyond the bulb

Important: Adequate lighting promotes cleanliness by exposing any unclean areas. Light diffusers (covers or shield) prevent contamination of food from glass fragments in the event of breakage.

It is recommended that the lighting levels specified in Table 5 be provided at working height.

**Table 5: Minimum illumination level (lux) for food premises**

Activity	Illumination level (lux)
Food preparation areas	500
Food and equipment storage areas	110-150
Dish washing, hand washing and toilet areas	200-300

## 10. Ventilation

### Food Safety Standard 3.2.3 (Food Premises and Equipment), Division 2, Clause 7

#### Required outcome

Food premises must have sufficient natural or mechanical ventilation to effectively remove fumes, smoke, steam and vapours from the food premises.

Handy hint: Always consider mechanical extraction systems when building new premises or renovating existing premises, as it is more expensive and inconvenient to install these systems once the business is operating.

#### Minimum requirements

##### Natural ventilation

- Natural ventilation is only suitable where there is little or no cooking that generates steam or greasy air.
- The premises must have openings, such as doors, windows and/or vents.

##### Mechanical ventilation

All food preparation areas where odours, fumes, smoke and steam are produced require a mechanical ventilation system that complies with Australian Standard 1668.1-1991 (The use of ventilation and air conditioning in buildings – Part 1) and Australian Standard 1668.2-1991 (The use of ventilation and air conditioning in buildings – Part 2) where:

- any cooking apparatus has:
  - a total maximum electrical power output exceeding 8 kilowatts (kW), or
  - a total gas power input exceeding 29 megajoules per hour (MJ/h), or

- the total maximum power input to more than one apparatus exceeds:
  - 0.5kW electrical power for each 1m<sup>2</sup> of floor area of the room or enclosure, or
  - 1.8MJ gas for each 1m<sup>2</sup> of floor area of the room or enclosure
- dishwashers and other washing and sanitising equipment that vent steam into the area to the extent that there is, or is likely to be, condensation collecting on walls and ceilings
- equipment installed on the premises after the mechanical ventilation system has been designed and installed must not impair the efficiency of the system or the natural ventilation.

##### Filters

Canopies are to be fitted with grease filters which can be removed for easy cleaning. The filter must comply with Australian Standard 1668.1-1991 (The use of ventilation and air conditioning in buildings) and the non-combustible requirements of Australian Standard 1530.1-1994 (Methods for fire tests on building materials, components and structures).

Note: Whilst Australian Standard 1668.2- 1991 has been superseded by Australian Standard 1668.2- 2002, Australian Standard 1668.2- 1991 still applies as the Building Code of Australia (BCA) includes Australian Standard 1668.2-1991 – The use of mechanical ventilation and air condition in building – Part 2: Mechanical ventilation for acceptable indoor- air quality (“the 1991 standard”). The Australian Building Code board has issued an advice dealing with the reasons for maintaining the reference to the 1991 standard in the BCA, rather than the 2002 standard.

### **Food premises exhaust hood airflow**

The airflow required for a food premises exhaust hood will depend on the:

- hood type
- cooking process
- length of the hood
- inside perimeter of the hood over all exposed sides
- height of the hood above cooking appliances

To determine the food premises exhaust hood airflow, refer to Appendix F of Australian Standard 1668.2-1991 (The use of ventilation and air conditioning in buildings – Part 2).

Certificates for both the design and construction of the hood are to be provided to Council by a qualified Mechanical Ventilation Engineer at the time of lodging plans and of the operation prior to the commencement of the business – see Figure 6

### **Storage racks**

Storage racks are not to be fitted above cooking and heating equipment as they can obstruct the airflow and trap droplets of oil.

### **Discharge point**

Effluent discharge is to be vertical at a minimum velocity of 5 metres per second (m/s) at the discharge point.

- The point of discharge is to be:
  - 1m above the ridge of a pitch roof
  - 3m above a flat roof
  - 6m from a property boundary
  - 6m from any air intake, natural ventilation or opening.
- Exhaust systems with a flow rate not exceeding 1000 litres per second (L/s) may receive a relaxation on the location of the discharge point.
- No exhaust can discharge over adjoining properties or where the discharge is less than 3m above any pedestrian thoroughfare including an accessible roof area.
- Exhaust ventilation for wood-fired and solid fuel cooking equipment needs to be separate to other ventilation systems and must not be combined with systems serving grease appliances, or oil generating or oil-heat appliances.

### **Dining areas**

Dining areas must be ventilated by natural or mechanical methods in accordance with the Building Code of Australia and Australian Standards.



**Figure 6: Example plan of a mechanical ventilation system (not to scale)**

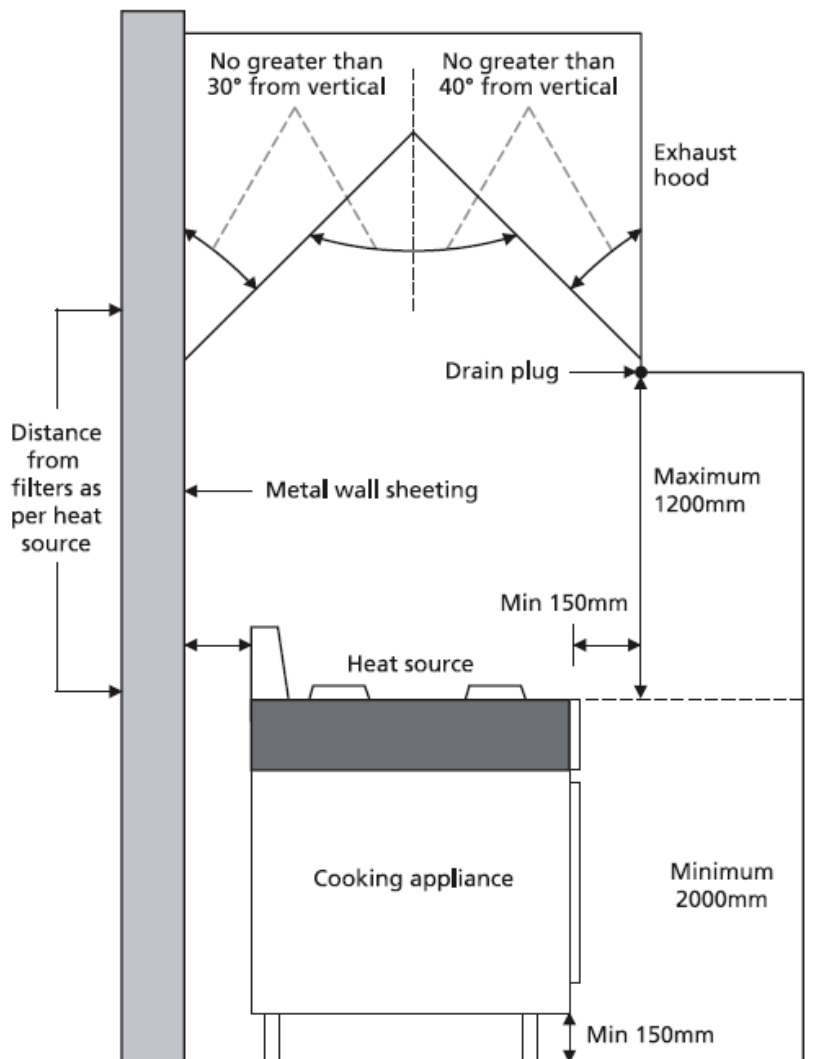

Note: For design specification, refer to AS :1668-1991 (Parts 1 and 2) All mechanical exhaust hood systems should be designed by a qualified and practising Mechanical Ventilation Engineer (AIRAH Certified) and upon completion to ensure compliance with the Australian Standard and the Building Code of Australian requirements.

Additional considerations: Consider the nuisance effects of noise and odour emissions upon the surrounding environment.

Ensure that lighting illumination is adequate within the cooking area. Avoid shadowing and utilise approved internal exhaust canopy lighting fixtures where necessary.

Where necessary, allow for all possible future expansion of cooking equipment.

## 11. Hand washing facilities

### Food Safety Standard 3.2.3 (Food Premises and Equipment), Division 4, Clause 14

#### Required outcome

The food premises must provide hand washing facilities located where they can be easily accessed by food handlers and:

- within areas where food handlers work if their hands are likely to be a source of contamination
- immediately adjacent to the toilets

Hand washing facilities must be:

- permanent fixtures
- provided with a supply of warm potable running water
- a size that allows easy and effective hand washing
- clearly designated for washing of hands, arms and face only
- be provided with a supply of liquid soap and approved hand drying facilities

#### Minimum requirements

Thorough washing and drying of hands is an essential activity in a food business to reduce the risk of food contamination and food-borne illness.

Hand washing basin(s) and facilities must be:

- located within an adequate distance, no more than 5m from all food handling areas
- located in or immediately adjacent to toilets
- provided with warm potable running water delivered through a single outlet

- provided with an adequate supply of liquid soap in a suitable dispenser in the immediate area
- provided with single-use paper towels and suitable dispenser or other approved hand drying facility in the immediate area of the hand basin
- of a suitable size to allow cleaning of hands and arms, with a minimum basin size of 11 litre (L) capacity and/or dimensions of 500mm x 400mm, and must be installed at bench height and appropriately fixed to the wall
- provided with an impervious splashback no less than 300mm high
- unobstructed by any other equipment and easily accessible
- not located under benches, ie an appropriate hand basin height is usually 900 mm off the floor

Splashguards may be required to prevent contamination of nearby equipment, benches or other areas from the hand washing facility. Rubbish containers located in the immediate area for the disposal of paper towels must be located and designed to prevent contamination of adjacent food contact surfaces, food, utensils cleaning equipment and storage areas.

Handy hint: Signage at hand wash basins, “Have you washed your hands?” and/or “Hand washing only”, is often a great reminder for staff. Signage must be sealed to walls to prevent pest harbourage.

## Best practice

Hand washing facilities at best should:

- be located at staff entrances to the food premises
- have a self-closing or metered tap to provide a flow of water for at least 15 seconds without the need to reactivate the tap
- be equipped with flow restrictors to reduce water consumption
- be provided with hands free devices (such as a knee operated lever, single lever taps or sensor taps).

## Exemptions

Food premises selling pre-packaged food only are not required to provide hand washing facilities.

For food premises that are used principally as a private dwelling, see section 20 “Bed and breakfast (B&Bs) and homestays” of this guide.

**Figure 7: Typical hand washing facilities**

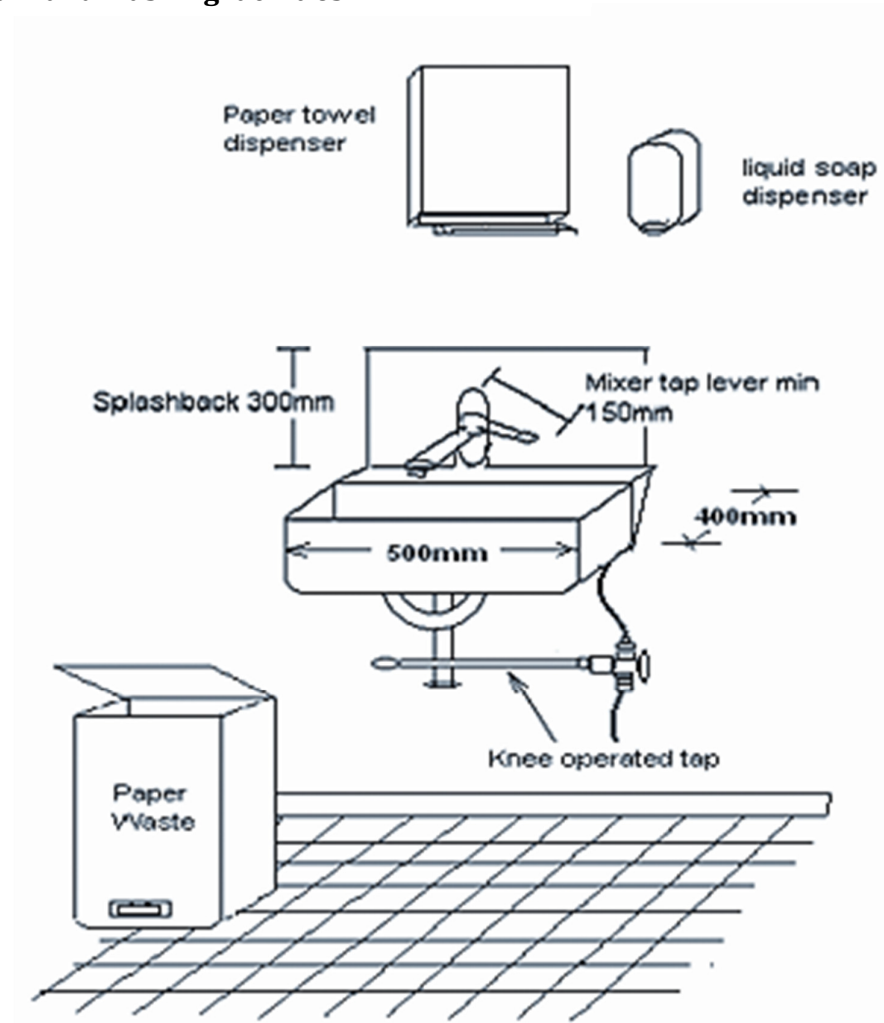

## 12. Toilet facilities

### **Food Safety Standard 3.2.3 (Food Premises and Equipment), Division 5, Clause 16**

#### **Required outcome**

A food business must ensure that adequate toilets are available for the use of food handlers working for the food business.

#### **Minimum requirements**

A food premises must comply with the requirements of the Building Code of Australia for provision of toilet facilities, including:

- number of toilets
- staff and public toilet facilities to be equipped with appropriate hand washing facilities
- toilet facilities to be clean and operate properly
- toilets located within the food premises are to be separated from areas where food is handled, displayed or stored by an air lock equipped with self-closing doors, or fitted with self-closing doors and provided with mechanical ventilation that operates when in use and thirty (30) seconds after the cubicle is vacated

#### **Best practice**

- Separate toilet facilities for both staff and customers should be provided.
- Toilet systems with ultra-low flush or dual flush toilets should be provided to reduce water consumption.
- Sensor controlled flush systems to male urinal should be installed to reduce wastewater consumption.
- Water-saving faucet aerators in public restrooms should be installed.

## 13. Water supply

### Food Safety Standard 3.2.3 (Food Premises and Equipment), Division 2, Clause 4

#### Required outcome

Food premises must have an adequate supply of potable water for all activities that use water that are conducted on the food premises. (Potable water is safe drinking water that is fit for human consumption.)

#### Minimum requirements

A food premises must meet the following criteria:

- constant hot and cold water must be available at all times, including during periods of high demand/ usage
- running potable water under pressure must be provided in sufficient quantity to carry out all food preparation, utensil washing, hand washing, cleaning and other water using operations
- warm potable water (ie hot and cold water provided through a single outlet) must be provided at all hand washing facilities to ensure effective hand washing procedures
- hot water unit(s) that is capable of delivering an adequate supply of hot water must be installed and located outside the food preparation area where possible
- hot water must be a sufficient temperature to effectively clean and sanitise equipment (see section 8 “Fixtures, fittings and equipment”)
- hot water that is provided to dishwashers must be supplied as per the manufacturer’s guidelines, e.g. sufficient pressure

### Premises not connected to town water supply

Premises that are not connected to a town water supply must ensure potable water is used in the food premises. This may require the implementation and maintenance of a treatment and monitoring system. Such a system may include filters, UV, ozone, chlorine and regular testing.

Handy hint: In order to conserve water and reduce costs, installation of flow control regulators or tap aerators is recommended. Water efficient tapware and low volume pre-rinse trigger sprays will also help save money and water.

For further information on water quality refer to the Australian Drinking Water Guidelines. A copy of these guidelines can be found at [www.nhmrc.gov.au](http://www.nhmrc.gov.au).

## 14. Sewage and wastewater disposal

### Food Safety Standard 3.2.3 (Food Premises and Equipment), Division 2, Clause 5

#### Required outcome

The food premises must have a sewage and wastewater disposal system that effectively disposes of sewage and wastewater, and is constructed and located so that it does not contaminate food or the water supply.

#### Minimum requirements

Food premises must provide appropriate facilities and plumbing infrastructure to ensure that sewage and all wastewater generated are disposed of appropriately. The food premises must be designed in accordance with the following criteria:

- The design (hydraulics plans) and installation of sanitary plumbing and drainage must comply with Australian Standard 3500.2:2003 (Plumbing and drainage – Sanitary plumbing and drainage) and be approved by your local water authority.
- Installation and maintenance of a grease trap designed to filter various oils generated from the food business operations (where applicable) is required. The installation and maintenance of a grease trap requires a Trade Waste Permit. For more information, contact your local water authority.
- Wastewater generated from mop buckets, cleaning mops and other cleaning activities must be disposed of in a cleaner's sink or other approved facility – see Figure 8.
- Access openings to the sanitary drainage system and grease traps must not be located in areas where there is a risk of food contamination. Note all access points to grease arrestors are to have a tight fitting lid that will not buckle, warp or rust to prevent the entry of pests and vermin.

- A food premises may utilise an approved drainage system for external waste storage to dispose of contaminated liquid waste.
- To allow effective floor cleaning procedures, cold rooms should have an external floor waste drain located adjacent to the door.
- Equipment generating liquid waste must be connected to an approved tundish for correct discharge, e.g. cold room evaporative units/liquid holding hot boxes, or removed in some other approved manner.

Important: Cross-connections and back flow may contaminate the potable water supply.

Figure 8: Example of cleaner's sinks

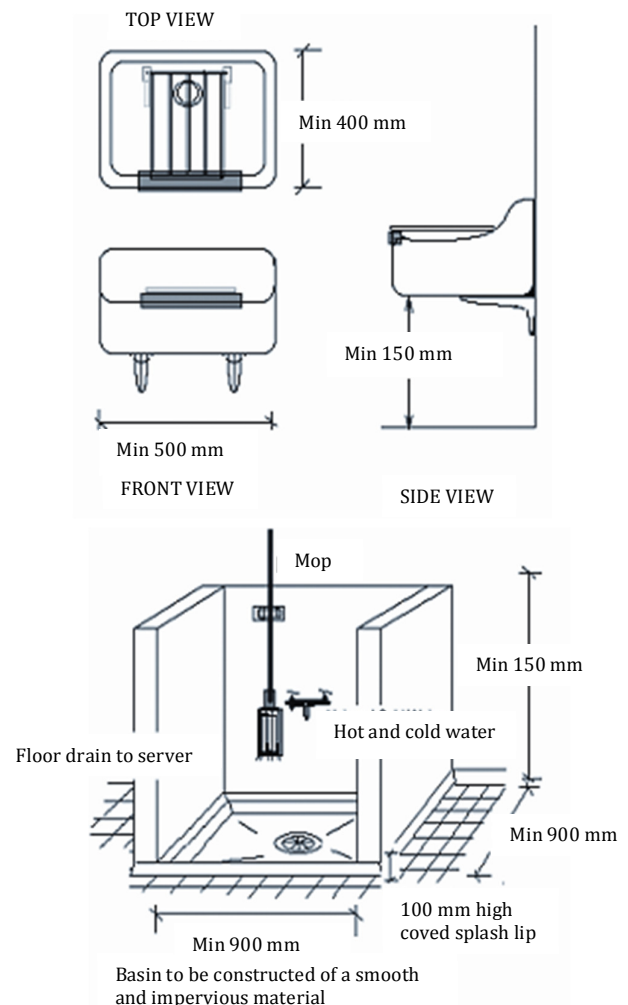

## 15. Storage of rubbish and recycling materials

### Food Safety Standard 3.2.3 (Food Premises and Equipment), Division 2, Clause 6

#### Required outcomes

Food premises must have facilities for the storage of rubbish and recycling materials that:

- are adequate to contain the volume and type of refuse on the food premises
- enclose the refuse to prevent access by vermin and animals
- are designed to be easily and effectively cleaned

#### Minimum requirements

Rubbish and recycling storage must:

- be adequate for the volume and type of waste produced by the business
- be able to be easily cleaned
- not provide a breeding ground or attract pests and vermin
- include an external area or a refuse room specifically for the storage of waste containers

#### External refuse and recycling storage areas must be:

- paved with an impervious material
- graded and drained to the sewer
- able to be easily cleaned
- capable of storing the rubbish generated from the business, eg wet waste, cardboard and general dry wastes, bulk waste oil

Consideration must be given to the location of waste storage areas and to their potential nuisance implications on neighbouring properties.

#### Rubbish and recycling containers

- Must be constructed of an impervious material such as metal or plastic.
- Fitted with tight fitting lids.
- Maintained in good condition to prevent the access of pests and vermin.
- Garbage chutes, where installed, must be constructed of impervious durable material, fitted and generally comply with the relevant waste laws or policies.
- Bins that cannot be lifted for cleaning are to have drainage bungs at the base

#### Rubbish rooms (where installed)

- Must be pest and vermin-proof.
- Must be constructed of a solid material and cement rendered or steel trowelled finish to a smooth surface.
- Floors and walls are to be of an impervious material and coved at the intersection.
- The floor is to be graded and drained to an approved floor waste and connected to sewer in an approved manner.
- Ventilated by natural or mechanical systems. If mechanical ventilation is used, it must comply with Australian Standard 1668-1991 (The use of ventilation and air conditioning in buildings - Parts 1 and 2).
- Fitted with a hose and tap connected to the water supply.

#### Best practice

- External refuse and recycling storage areas- covered and provided with a hose and tap connected to a water supply
- Rubbish rooms- air conditioned to minimise nuisance.

Handy hint: Any external waste storage areas are to comply with the relevant waste laws.

## 16. Storage facilities

### **Food Safety Standard 3.2.3 (Food Premises and Equipment), Division 5, Clause 15**

#### **Required outcomes**

Food premises must have adequate storage facilities for items that are likely to be a source of food contamination, including chemicals, clothing and personal belongings.

Storage facilities must be located where there is no likelihood of stored items contaminating food or food contact surfaces.

#### **Minimum requirements**

##### **Dry goods and food packaging materials**

Adequate storage must be provided for dry goods and packaging materials in a sealed and lined, vermin-proof room with approved flooring.

##### **Cleaning chemicals and equipment**

Chemicals, cleaning equipment, pest control chemicals and equipment are to be:

- enclosed in cupboards located away from the preparation and storage of food where there is no likelihood of stored items contaminating food or food contact surfaces
- designated for that use only

##### **Clothing and personal effects**

Adequate facilities must be provided for staff to store personal belongings that consist of either:

- a change room, or
- enclosed cupboards for the storage of clothing and personal belongings, located away from the food preparation and storage areas.

##### **Office materials**

Storage of paper work and other materials associated with the administration of the business must be stored in a room designated for that use or in enclosed cupboards or drawers designated for that use, separate from food preparation and storage areas.



## 17. Temperature measurement

### Food Safety Standard 3.2.2 (Food Premises and Equipment), Division 6, Clause 22

#### Required outcome

A food business where potentially hazardous food is handled must have a temperature monitoring device that:

- is readily accessible
- can accurately measure the temperature of potentially hazardous foods

#### Minimum requirements

All food premises where potentially hazardous foods are handled must have a temperature measuring device with an accuracy of  $\pm 1^{\circ}\text{C}$  that is easily accessible at all times.

An example of a suitable thermometer includes:

- stainless steel digital probe thermometer that can be placed into food to accurately measure core temperatures
- a thermometer that is easily and effectively cleaned and, when necessary, sanitised

A thermometer can be cleaned by rinsing the probe under warm water; sanitised by alcohol wipes or similar proven method.

#### Best practice

In addition to having a probe thermometer a food business may also have available:

- An infrared thermometer to measure the surface temperature only of the food without touching the food.
- Externally mounted, highly visible temperature gauges on all refrigeration and heating equipment that are monitored and calibrated.

Important: A food business is required to maintain the temperature of potentially hazardous food either at or below  $5^{\circ}\text{C}$  or at or above  $60^{\circ}\text{C}$  (in accordance with the manufacturer's instructions) during the receipt, processing (cooking, cooling, reheating), storage, transport and display. Documenting temperatures of products on a daily basis is a great way to assist in maintaining good food safety practices.

**Figure 9: Example of an approved temperature measuring device accurate to  $\pm 1^{\circ}\text{C}$**

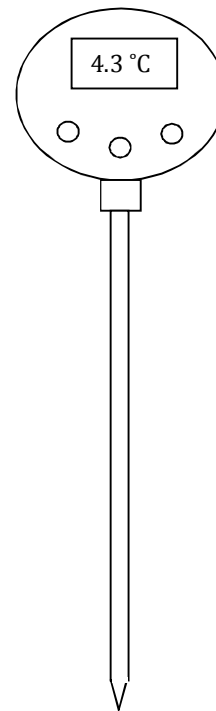

## 18. Food transport

### **Food Safety Standard 3.2.3 (Food Premises and Equipment), Division 5, Clause 17**

#### **Required outcome**

- Vehicles used to transport food must be designed and constructed to protect food if there is a likelihood of food being contaminated during transport.
- Parts of the vehicle and food contact surfaces used during transport must be designed and constructed so that they can be effectively cleaned.

#### **Minimum requirements**

- Food must always be transported in a way that minimises the risk of contamination.
- Food transport vehicles that store potentially hazardous food must be capable of maintaining product at required temperatures at or below 5 °C or, at or above 60 °C.
- The design of a food transport vehicle and containers must allow for easy cleaning procedures and protect transported food against contamination.
- Food transport vehicles must be approved by Council.

## 19. Mobile food vehicles

### Required outcome

When designing and fitting out a mobile food vehicle, it must meet the required outcomes from the Food Safety Standards – just as with a restaurant, takeaway food outlet or café.

### What is a mobile food vehicle?

Mobile premises, for a food business, means premises that are a vehicle from which a person sells unpackaged food by retail. A mobile food vehicle has specific design requirements that need to be considered.

### Minimum Requirements

#### Walls, floors and ceiling

- Walls, floors and ceiling of the food preparation and storage areas of the vehicle must comply with sections 6 and 7 of this guide

#### Door and service openings

- Doors and serving hatches are to be finished on both internal and external sides with the same standard of material as the walls.
- The driving compartment of the vehicle must be separated and sealed from the food preparation and storage section.
- All openings on the mobile food vehicle are to be fitted with close-fitting doors and shutters. These must be vermin-proof and able to be closed during transport.

#### Washing

- A storage tank with at least a 90L capacity must be installed in the vehicle. This tank needs to be filled with potable water and have an attached pressure supply system reticulated to sinks and basins.

- A wastewater tank of adequate capacity (normally 100L capacity) must be fitted to the vehicle. A back flow prevention device should be fitted to prevent any possible source of contamination.

### Rubbish disposal

- Separate rubbish containers with tight-fitting lids must be fitted. Bin liners must be provided.

### Use of the premises

- Mobile food vehicles cannot be used for sleeping or any other activity that has the potential to contaminate food prepared or stored in the vehicle.

### Special requirements

- The vehicle (if it is a road vehicle) must be registered.
- If the mobile food vehicle is to be used to sell food on public land (including roads), contact Council for information on Roadside Vending Permits.
- The installation and use of liquid petroleum gas must comply with the relevant legislation. A current gas certificate needs to be available for inspection at all times.
- Noise from the operation of the vehicle is to be within the requirements of the Environmental Protection Act 1994 or relevant Local Law.

See Appendix 4 for an example copy of mobile food vehicle plans.

Important: Facilities must be provided for emergency fire control. It is recommended to provide a minimum 4 kg Dry Chemical AB (E) fire extinguisher (within its expiry period) and a fire blanket located within close proximity to cooking equipment.

## 20. Bed and breakfast (B&Bs) and homestays

### Development Approval

Ensure the site has a relevant Development Approval.

### Required outcome

B&Bs and homestays providing meals as part of the business also need to comply with the Food Standards in this guide. These types of premises often accommodate a small number of people and do limited amounts of cooking. For this reason, alternative solutions can be applied to these businesses.

### Minimum requirements

#### Walls

- Must be smooth, impervious and easily cleaned. An example of an alternative is well-painted materials, such as tongue and groove. While this is not acceptable in commercial operations, minor alterations could make this material adequate for B&Bs and homestays.

#### Floors

- Must be smooth, impervious and easy to clean. Materials, such as polished cork and polished floorboards, are acceptable.

#### Benches and cupboards

- Domestic style benches are acceptable if they are in good condition and have impervious surfaces.

#### Hand wash basins

- A basin for hand washing must be located in or close to the food preparation area. These basins must have a supply of warm potable water, liquid soap and paper towels or other approved hand drying devices.

### Dishwashing

- Two methods can be used for dishwashing: a double bowl sink, or a dishwasher and a single bowl sink.

### Ventilation

- Refer to section 10 “Ventilation”.
- In domestic premises, the type and size of cooking appliances is usually not within the scope of Australian Standard 1668-1991 (The use of ventilation and air conditioning in buildings). Domestic mechanical systems are usually sufficient to remove greasy fumes produced by cooking. Contact Council for advice on the right mechanical ventilation before installation. The system needed will depend on the type of equipment you will be operating and the amount of cooking being done.

### Potable Water Supply

- Refer to section 13 “Water supply”

### Storage Facilities

- A dedicated storage area specific for the storage of cooking utensils and food should be provided. This area is to be separate from domestic supplies.

## 21. Appendix 1 - key definitions

### **Adequate supply of water**

Potable water available at a volume, pressure and temperature adequate for the purposes for which the water is used.

### **Australian/New Zealand Standards**

Australian Standard/New Zealand Standards are documents which are referenced by legislation to provide more detail on requirements and technical procedures. These standards can be purchased from Standards Australia on 131 242 or by visiting its website at [saiglobal.com](http://saiglobal.com).

### **Bed & Breakfasts (B&Bs)**

A dwelling providing commercial, short-term guest accommodation.

### **Contaminant**

Contaminant means any biological or chemical agent, foreign matter or other substances that may compromise food safety or suitability.

### **Coving**

A curved junction between the floor and the wall.

### **Contamination**

The introduction or occurrence of a contaminant in food.

### **Easily moveable**

Equipment that can be moved by one person (either on wheels, castors or sitting on the surface) to enable cleaning as often as necessary to ensure that, for example, food debris can be swept from underneath and the floor mopped. If the equipment cannot be easily moved, a clearance space must be provided so the surrounding area and beneath the equipment can be cleaned without moving the appliance.

### **Equipment**

Means a machine, instrument, apparatus, utensil or appliance - other than a single use item - used or intended to be used in or in connection with food handling, and includes any equipment used or intended to be used to clean the food premises or equipment.

### **Food business**

A business, enterprise or activity (other than primary food production) that involves:

- handling of food intended for sale, or
- sale of food regardless of whether the business enterprise or activity concerned is of a commercial, charitable or community nature or whether it involves the handling or sale of food on one occasion only.

### **Food premises**

Any premises including land, vehicles, parts of structures, tents, stalls and other temporary structures, boats, pontoons, including premises used principally as a private dwelling, but does not mean food vending machines or vehicles used only to transport food.

### **Food Safety Standards**

These are part of the Food Standards Code and define requirements for food premises on food handling practices and the structural requirements of food premises.

### **Handling of food**

Includes the making, manufacturing, producing, collecting, extracting, processing, storing, transporting, delivering, preparing, treating, preserving, packing, cooking, thawing, serving and displaying of food.

### **Homestay**

A dwelling providing short-term guest accommodation.

### **Potable water**

Potable water is safe drinking water that is fit for human consumption.

### **Potentially hazardous food**

Food that has to be kept at certain temperatures to minimise the growth of any pathogenic micro-organisms that may be present in the food and/or to prevent the formation of toxins. This may include meat, seafood, dairy products, orange juice and cooked rice.

### **Rinsing baskets**

Containers usually of wire or heat resistant plastic or perforated steel that can be submerged in hot water to sanitise utensils.

### **Safe and suitable food**

Food is considered safe if it is unlikely to cause physical harm to a person who might later consume it, assuming they treated the food correctly after purchase. Food is considered suitable if it is not damaged, deteriorated or perished to an extent that affects its intended use, e.g. out of date, poor maintenance or poor storage of chemicals, or contains a substance that is foreign to the nature of the food, i.e. foreign matter or chemicals which may have fallen into the food.

### **Sanitising**

A process that significantly reduces the number of micro-organisms present on a surface. This is usually achieved by the use of hot water and or chemical sanitisers.

### **Sewage**

Discharge from toilets, urinals, basins, showers, sinks and dishwashers through a sewer or other means.

### **Sinks**

Includes sinks for food preparation, cleaner's sink, utensil and equipment washing, and personal hand washing basins.

### **Temperature control**

Maintaining potentially hazardous food at a temperature of:

- 5°C or below is necessary to minimise the growth of infectious or toxin producing micro-organisms in the food so that the microbiological safety of the food will not be adversely affected for the time the food is at that temperature, or
- 60°C or above, or
- another temperature - if the food business demonstrates that maintenance of the food at this temperature for the period of time for which it is so maintained will not adversely affect the microbiological safety of the food.

### **Warm water**

Not hotter than 50 °C - to comply with Australian Standard 3500.4:2003 (Plumbing and drainage: Part 4 – heated water services)

## 22. Appendix 2- example plans

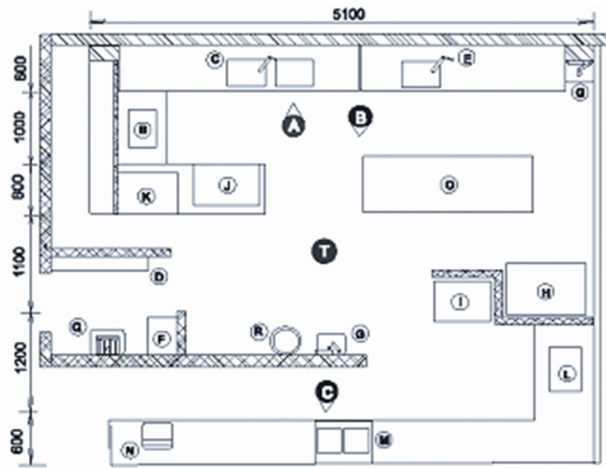

**FLOOR PLAN**

- A Mechanical exhaust
- B Fryer
- C Stainless steel
- D Staff personal effects storage
- E Stainless food preparation sink
- F Chemical storage unit
- G Stainless steel hand wash basin 400mm by 500mm
- H Upright scope commercial refrigeration unit
- I Scope upright drinks fridge
- J Dry goods pantry
- K Commercial pie warmer
- L Coffee
- M Refrigerated display cabinet
- N Cash register
- O Stainless steel food preparation bench
- P General waste bin
- Q Cleaners sink
- R Waste bin
- S Storage cupboard
- T Floor waste drain

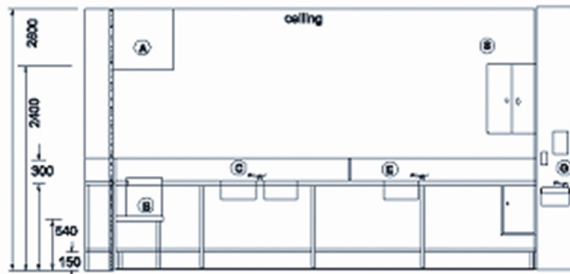

**VIEW 'A'**

ceiling

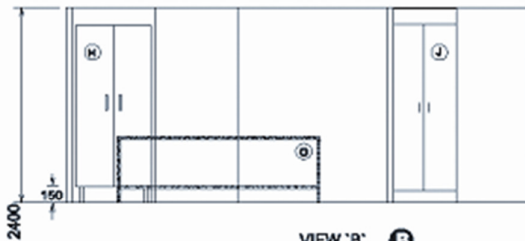

**VIEW 'B'**

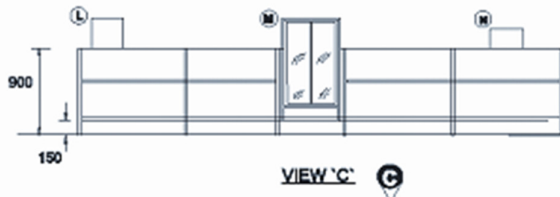

**VIEW 'C'**

- FLOOR Ceramic tiles and coving to all walls.
- WALLS Timber framing.
- WALL LINING 10mm plasterboard gloss enamel finish.
- BENCHES Stainless steel bench and frame.
- FRONT COUNTER Laminex bench top.
- CEILING Sealed plasterboard tiles gloss enamel finish.

- PLUMBING ss basin, knee operated mixer tepid & cold water ss sinks, lever mixer tap, hot and cold water.
- BACKFLOW PREVENTION Air gap to all tapware. Dual check valve to coffee machine.

## 23. Appendix 3 – 2D example plans

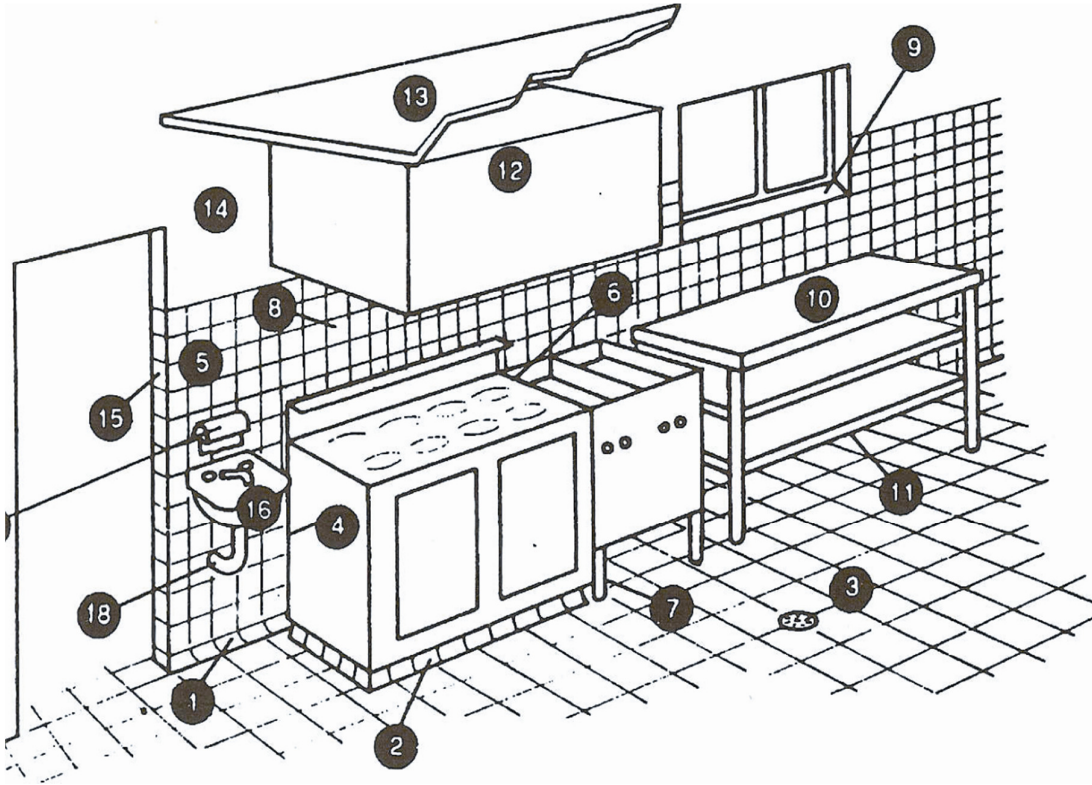

### Requirements – typical food preparation area

1. Floor/wall coving as per section 6	10. Preparation bench – steel framed
2. Plinth not less than 100mm high	11. Bottom shelf – min 250mm above floor
3. Impervious floor graded and drained	12. Mechanical exhaust ventilation canopy
4. Fittings sealed to wall or 200mm clear of wall	13. Rigid smooth faced ceiling
5. Walls finished as per section 7	14. Smooth cement rendering
6. Sealing between fittings	15. No timber door frames
7. Legs 150mm minimum	16. Hand basin, hot and cold water mixing set
8. No storage shelves below canopy	17. Soap and towel dispenser
9. Splayed windowsill 300mm above preparation bench	18. Water and drainage pipes concealed in wall



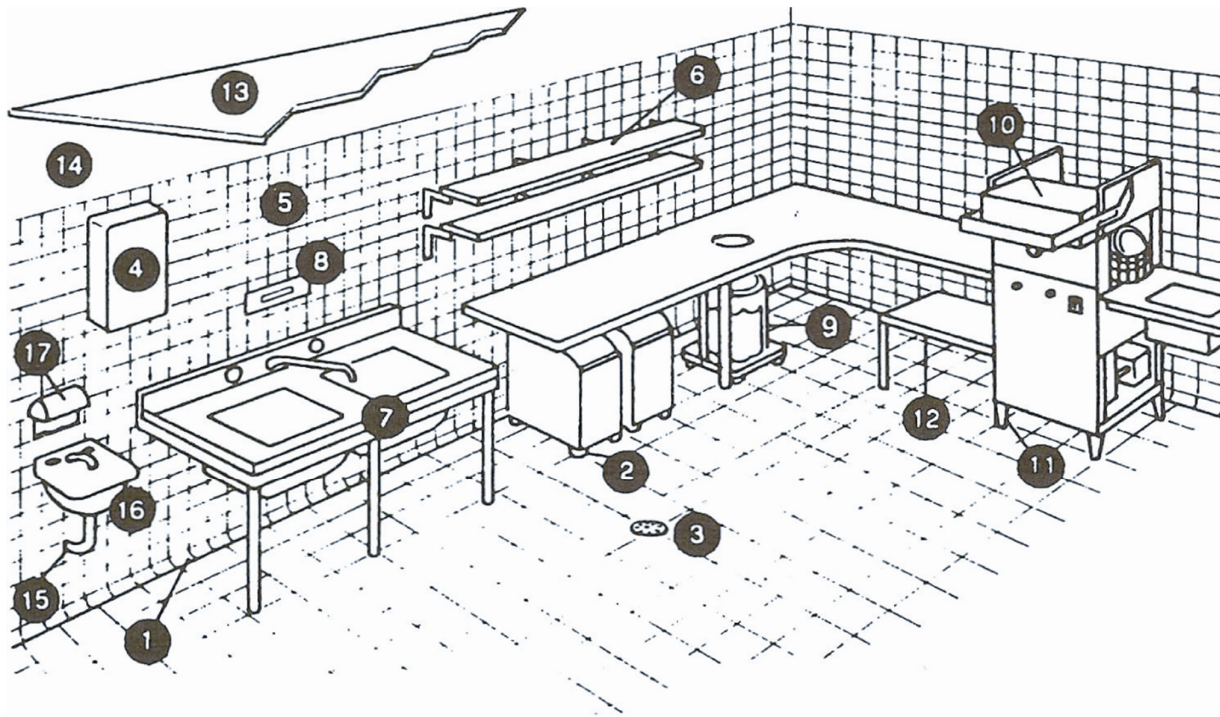

### Requirements - typical wash-up area

1. Floor/wall coving	10. Dishwasher with temperature indicating device
2. Casters to under-bench storage	11. Legs - 250mm minimum
3. Impervious floor graded and drained	12. Bottom shelf - minimum 250mm above floor
4. Hot water heater sealed to wall	13. Rigid smooth faced ceiling
5. Walls finished as per section 7 of this guide	14. Smooth cement rendering
6. Shelving - 40mm clear of wall	15. Water and drainage pipes concealed into walls
7. Sink unit on metal frame	16. Hand basin, hot and cold water mixing set
8. Thermometer	17. Soap and towel dispenser
9. Garbage receptacle	

## 24. Appendix 4 - example plans of a mobile food vehicle

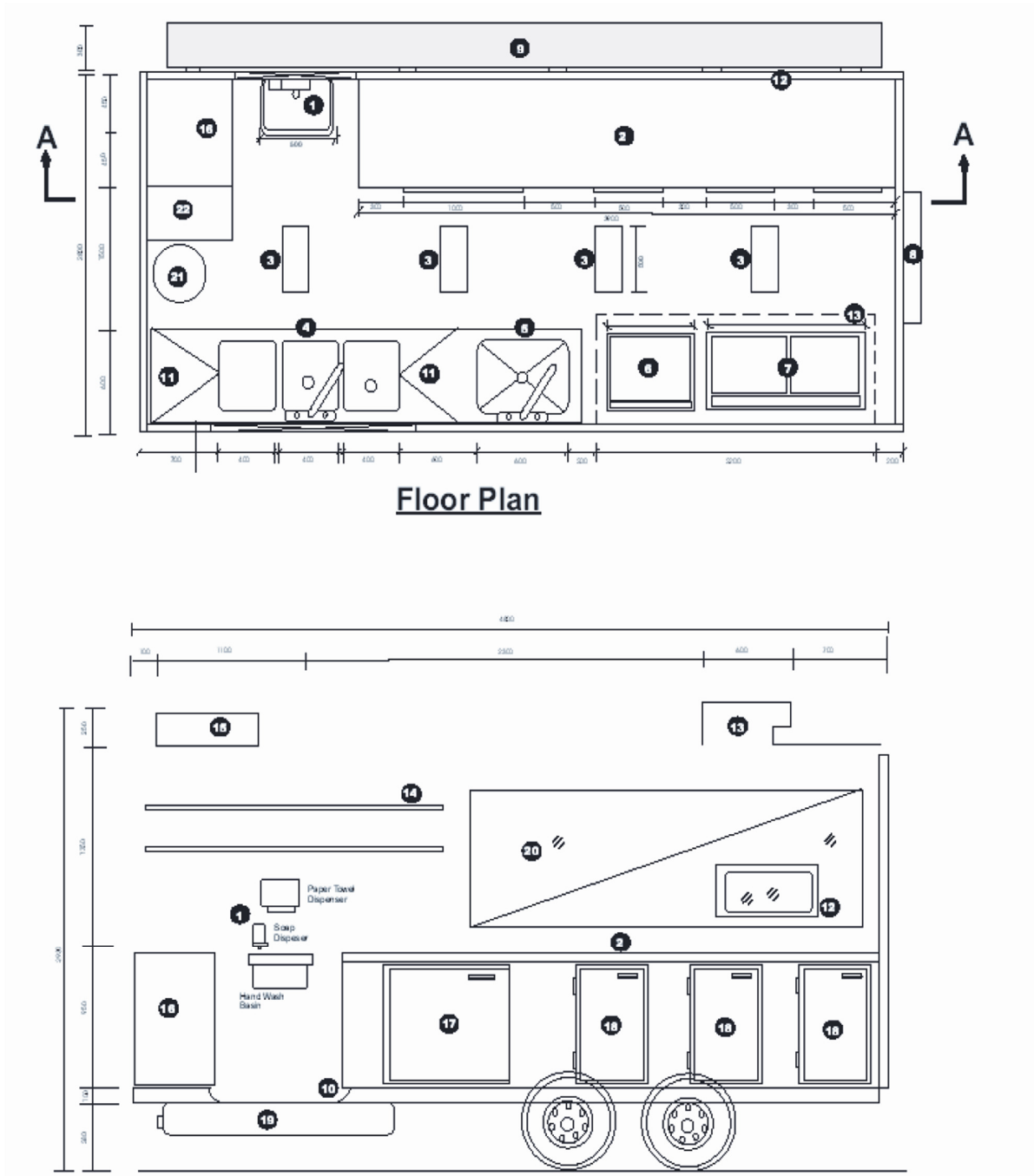

### Legend - example plans of a mobile food vehicle

1. Stainless steel hand wash basin provided with hot and cold water through single spout 450mm by 450mm. Knee operated basin supplied with liquid soap and paper towel dispensers fixed directly above	13. Mechanical exhaust extraction unit compliant with AS 1668: 2002 Part 1 & 2 discharge vent screened to prevent pest and vermin entry
2. Food preparation bench stainless steel construction	14. Stainless steel shelving sealed to wall
3. Ample fluorescent lighting - 30watt 12 volt DC	15. 250L gravity portable water storage unit tank - food grade reinforced plastic
4. Three compartments/ dishwasher sink (hot and cold mixed water faucet) 300(w) by 400mm(l) by 300mm(d)	16. Storage cupboards – personal effects, cleaning equipment/ chemicals
5. Food preparation/large pot wash sink (hot and cold mixed water faucet) 600mm(w) by 550mm(l) by 400mm(d)	17. Gas operated commercial stainless steel freezer unit fitted with external temperature gauges accurate to +/-1°C
6. Cooltop/Grill natural gas fitted with large wheels for cleaning requirements	18. Gas operated commercial stainless steel refrigeration unit fitted with external temperature gauges accurate to +/-1°C
7. Commercial natural gas deep fryer with large wheels for cleaning requirements	19. Primary waste water tank 90L
8. Self-closing entrance door	20. Window
9. Stainless steel folding table	21. Swing window perspex for protection from exterior dust
10. Commercial grade seamless vinyl flooring covered to walls	22. Waste bin with close fitting lid
11. Stainless steel folding table	23. Dry goods storage pantry
12. Self-closing screened pass-out window	

**For further information contact your local Council**